

LED vehicle Arrow Signal Module Specification and Requirements Checklist 12” (300 mm) Omni-directional Arrows

October 20, 2008

Agency Name:

Project:

Date:

1 Overview

1.1 Purpose

1.1.1 The purpose of this specification is to provide the minimum performance requirements for *Omni-Directional* 300 mm (12 in) Light Emitting Diode (LED) vehicle arrow traffic signals. This specification refers to procedures and definitions as described in the **Vehicle Traffic Control Signal Heads- Light Emitting Diode (LED) Vehicle Arrow Traffic Signal Supplement (VTCSH), Adopted July 1, 2007**, Published by the Institute of Transportation Engineers (ITE) and contains additional requirements to ensure optimum long term reliability and performance.

1.2 Manufacturer Requirements and Approvals

1.2.1 Manufacturers supplying products to this specification must be a registered participant and have the base part numbers being provided listed on the *Intertek-ETL LED Traffic Signal Modules Certification Program* approved products website.

1.2.2 All LED Traffic Signal Modules shall be produced in a NAFTA participating country.

1.2.3 All LED Traffic Signal Modules supplied to this specification shall be CSA Approved.

2 Physical and Mechanical Requirements

2.1 General

2.1.1 Modules shall fit into existing traffic signal housings built to the VTCSH Standard without modification to the housing, or shall be stand-alone units that incorporate a housing meeting the performance and design requirements of the VTCSH Standard.

2.1.2 Installation of a module into an existing signal housing shall not require the use of special tools. The module shall connect directly to the existing electrical wiring system.

2.2 LED Signal Module

2.2.1 A module shall be designed as replacement for the existing optical components or signal module in a signal housing, or shall provide a complete replacement of the signal head.

2.2.2 The module lens shall be hard coated or otherwise made to comply with the material exposure and weathering effects requirements of the Society of Automotive Engineers (SAE) J576.

2.2.3 Tinted or Clear Lens. Unless designated otherwise in the below table the standard lens color shall be tinted with a color similar to the colors required in paragraph 3.2, Chromaticity for all Red and Yellow modules and clear for all Green modules.

	300mm (12") Arrows	
	Tinted	Clear
Red		
Yellow		
Green		

2.2.4 The module lens shall have a convex smooth exterior surface to minimize the build-up of dust and dirt.

2.2.5 The general configuration of the arrow icon is illustrated in Figure 2. The arrow should be oriented in the direction of its intended use. LED vehicle arrow traffic signal modules shall be manufactured for use as omnidirectional arrows.

2.2.6 All LEDs utilized to illuminate Arrow traffic signal modules, shall be LEDs that have been manufactured utilizing materials that have industry acceptance as being suitable for uses in outdoor applications. At no time is the use of LEDs that utilize AlGaAs technology acceptable.

2.3 Environmental Requirements

2.3.1 All exposed components of a module shall be suitable for prolonged exposure to the environment, without appreciable degradation that would interfere with function or appearance. As a minimum, selected materials shall be rated for service for a period of a minimum of 60 months in a south-facing Arizona Desert installation.

2.3.2 A module shall be rated for use throughout an ambient operating temperature range, measured at the exposed rear of the module, of -40°C (-40°F) to +74°C (+165°F).

2.3.3 A module shall be protected against dust and moisture intrusion, including rain and blowing rain per Mil-Std-810F Method 506.4, Procedure 1.

2.4 Construction

2.4.1 A module shall be a self-contained device, not requiring on-site assembly for installation into an existing traffic signal housing. The power supply for the module shall be integral to the signal module.

2.4.2 Assembly and manufacturing processes for the module shall be designed to assure all internal LED and electronic components are adequately supported to withstand mechanical shock and vibration due to high winds and other sources.

2.5 Materials

2.5.1 Materials used for the lens and module construction shall conform to ASTM specifications for the materials where applicable. All lenses shall be hard coated to protect the lens from abrasion.

2.5.2 Enclosures containing either the power supply or electronic components of the module shall be made of UL94 flame retardant materials. The lens is excluded from this requirement.

2.6 Module Identification

2.6.1 Each module shall be identified on the backside with the manufacturer's name, model, operating characteristics and serial number. The operating characteristics identified shall include the nominal operating voltage and stabilized power consumption, in watts and Volt-Amperes.

2.6.2. Omni-directional modules shall be clearly marked with the phrase "Suitable for mounting in any orientation".

2.6.3 Modules conforming to all non-optional requirements of this specification, shall have the following statement on an attached label: "Manufactured in Conformance with the ITE LED Vehicle Arrow Traffic Signal Supplement".

2.6.4 All modules must be labeled with the ETL Verified label shown in Figure 1. This label designates the compliance and listing with the Intertek-ETL Traffic Signal Certification Program.

3 Photometric Requirements

3.1 Luminous Intensity, Uniformity & Distribution

3.1.1 Minimum maintained luminous intensity: When operated under the conditions defined in Sections 2.3.2 and 4.2.1, the luminous intensity values for modules shall not be less than the values calculated using the method described below for a minimum period of 60 months.

3.1.1.1 For omni-directional LED vehicle arrow traffic signal modules, calculate the intensity factor ($f(I_{OD})$) for the range from 27.5 degrees up to 27.5 degrees down, and for 27.5 degrees left to 27.5 degrees right using the following equation:

$$f(I_{OD}) = 1.02 * e^{(-0.0038 * \theta_{OD}^2)}$$

where: $\theta_{OD} = \cos^{-1}(\cos(\theta_{Vert}) * \cos(\theta_{Horiz}))$, θ_{Vert} is the angle measured above or below a horizontal plane perpendicular to the face of the module lens, and θ_{Horiz} is the angle measured to the left or right from a vertical plane perpendicular to the face of the module lens. All angles are measured in degrees. Round the result to two significant figures.

3.1.1.1.1 Multiply the intensity factor ($f(I_{OD})$) by the appropriate peak minimum maintained luminous intensity value for the specified module color: Red—58.4 cd, Yellow—145.6 cd, and Green—76.0 cd. Round the resultant value of the luminous intensity to the first decimal place.

3.1.1.1.2. For the region where θ_{Vert} is between 2.5 degrees up and 2.5 degrees down, and θ_{Horiz} is between 2.5 degrees left and 2.5 degrees right, the values shall be the same as those calculated for $\theta_{Vert} = 2.5$ degrees and $\theta_{Horiz} = 2.5$ degrees.

3.1.1.1.3. There are no requirements for the region where $\theta_{OD} > 30$ degrees.

3.1.1.2 Table 1 provides the minimum maintained luminous intensity values for omni-directional modules, over the required angular range.

3.1.2 Maximum permissible luminous intensity: When operated within the temperature range specified in Section 2.3.2, the actual luminous intensity for a module shall not exceed three times the required peak value of the minimum maintained luminous intensity for the selected signal color.

3.1.3 Luminance uniformity: The uniformity of the signal output across the emitting section of the module lens (i.e. the arrow icon) shall not exceed a ratio of 10 to 1 between the maximum and minimum luminance values (cd/m^2).

3.2 Chromaticity

3.2.1 Color regions: The measured chromaticity coordinates of modules shall conform to the color regions specified in the VTCSH LED Circular Signal Supplement.

3.2.2 Color uniformity: The uniformity of the emitted color of a module shall conform to the requirements specified in the VTCSH LED Circular Signal Supplement.

4. Electrical

4.1 General

4.1.1. All wiring and terminal blocks shall meet the requirements of Section 13.02 of the VTCSH standard. Two secured, color coded, 600V, jacketed wires, a minimum of 20 AWG and at least 1 meter (39 in) in length, conforming to the NFPA 70, National Electrical Code, and rated for service at +105°C, shall be provided.

4.1.2 The following color scheme shall be used for all modules AC power leads: White for Common, Red for the Red arrow signal, Yellow for the Yellow arrow signal, and Brown for the Green arrow signal.

4.1.3 The AC power leads shall exit the module via a rubber grommetted strain relief, and shall be terminated with insulated female quick connect terminals with spade / tab adapters. The leads shall be separate at the point at which they leave the module.

4.1.3.1 All external wiring utilized in the LED traffic signal module shall be anti-capillary type wire to prevent the wicking of moisture to the interior of the module.

4.1.4 All power supplies shall be conformal coated for additional protection.

4.2 Voltage Range

4.2.1 The modules shall operate from a 60 ± 3 Hertz AC power line over a voltage range from 80 to 135 VAC RMS.

4.2.2 Fluctuations in line voltage over the range of 80 to 135 VAC RMS shall not affect luminous intensity by more than ± 10 percent.

4.2.3 To prevent the appearance of flicker, the module circuitry shall drive the LEDs at frequencies greater than

100 Hz, when modulated or at DC over the voltage range specified in Section 4.2.1.

4.2.4 Low Voltage Turn Off: There shall be no visible illumination from the module when the applied voltage is less than 35 VAC RMS.

4.2.5 Turn-ON and Turn-OFF Time: A module shall reach 90% of full illumination (turn-ON) within 75 msec of the application of the nominal operating voltage. The signal shall cease emitting visible illumination (turn-OFF) within 75 msec of the removal of the nominal operating voltage.

4.3 Transient Voltage Protection

4.3.1 The on-board circuitry of a module shall include voltage surge protection, to withstand high-repetition noise transients and low-repetition high-energy transients as stated in Section 2.1.8, NEMA Standard TS 2-2003.

4.3.1.1 In addition to the transient test requirements defined in the Design Qualification Testing section of this specification all power supplies used in the circular signals supplied to this specification shall be capable of passing an additional ring-wave surge testing in accordance with the IEEE Recommended Practice on Characterization of Surges in Low-Voltage (1000V and less) AC Power Circuits, ANSI/IEEE C62.41.2-2002, 6KV, 100 kHz ring-wave with an output impedance of 30ohms. The short circuit current shall be 200 Amps.

4.4 Electronic Noise

The LED signal and associated on-board circuitry shall meet the requirements of the Federal Communications Commission (FCC) Title 47, Subpart B, Section 15 regulations concerning the emission of electronic noise by Class A digital devices.

4.5 Power Factor (PF) , AC Harmonics, and Power

4.5.1 Modules shall provide a power factor of 0.90 or greater when operated at nominal operating voltage and at 25 ° C (77°F).

4.5.2 Total harmonic distortion induced into an AC power line by a module at nominal operating voltage, and at 25°C (77°F), shall not exceed 20%.

4.5.3 Typical power at 25° C for the arrows modules shall be 6 watts for all colors.

4.6 Controller Assembly Compatibility

4.6.1 The current draw shall be sufficient to ensure compatibility and proper triggering and operation of load current switches and conflict monitors in signal controller units.

4.6.2 Off State Voltage Decay: When the module is switched from the On state to the Off state the terminal voltage shall decay to a value less than 10 VAC RMS in less than 100 milliseconds when driven by a maximum allowed load switch leakage current of 10 milliamps peak (7.1 milliamps AC).

4.7 Failed State Impedance

The module shall be designed to detect catastrophic loss of the LED load. Upon sensing the loss of the LED load, the module shall present a resistance of at least 250 kΩ across the input power leads within 300 msec. The LED light source will be said to have failed catastrophically if it fails to show any visible illumination when energized according to Section 4.2.1 after 75 msec.

5. Quality Assurance

5.1 General

5.1.1 Quality Assurance Program: Modules shall be manufactured in accordance with a vendor quality assurance (QA) program. The QA program shall include two types of quality assurance: (1) design quality assurance and (2) production quality assurance. The production quality assurance shall include statistically controlled routine tests to ensure minimum performance levels of modules built to meet this specification.

5.1.2 Record Keeping: QA process and test results documentation shall be kept on file, and available for viewing, for a minimum period of seven years.

5.1.3 Conformance: Module designs not satisfying design qualification testing and the production quality assurance testing performance requirements in Sections 5.3 and 5.4 shall not be labeled, advertised, or sold as conforming to this specification.

5.1.4 Potential suppliers must complete and submit the LED Module Supplier checklist shown in Table 2 and provide a copy of the checklist with the submission of any proposals.

5.2 Manufacturers Serial Numbers

Each module shall be identified with the information specified in paragraph 2.6.1.

5.3 Production Tests & Inspections

5.3.1 Production Test Requirements: All modules tendered for sale shall undergo the following Production Testing & Inspection prior to shipment. Failure of a module to meet the requirements of Production Testing & Inspection shall be cause for rejection. Test results shall be maintained per the requirement of Section 5.1.2.

5.3.1.1 All Production Tests shall be performed at an ambient temperature of 25°C (77°F) and at the nominal operating voltage of 120 VAC.

5.3.2 Luminous Intensity: All modules shall be tested for luminous intensity. A single point measurement, with a correlation to the intensity requirements of Sections 3.1.1 and 3.1.2 may be used. The purchaser may specify additional measurements. Failure of a module to meet the requirements for minimum maintained luminous intensity (3.1.1) or maximum permissible luminous intensity (3.1.2) shall be cause for rejection of the module.

5.3.3 Power Factor: All modules shall be tested for power factor per the requirements of Section 4.5.1. A commercially available power factor meter may be used to perform this measurement. Failure of a module to meet the requirements for power factor (4.5.1) shall be cause for rejection of the module.

5.3.4 Current Consumption Measurement: All modules shall be measured for current flow in Amperes. The measured current values shall be compared against the design current values from design qualification measurements in Section 5.4.6.1. A measured current consumption in excess of 120% of the design qualification current value for an ambient temperature of 25°C (77°F) shall be cause for rejection of the module.

5.3.5 Visual Inspection: All modules shall be visually inspected for any exterior physical damage or assembly anomalies. Careful attention shall be paid to the surface of the lens to ensure there are no scratches (abrasions), cracks, chips, discoloration, or other defects. The presence of any such defects shall be cause for rejection of the module.

5.4 Design Qualification Testing

5.4.1 Design Qualification Test Requirements. Design qualification testing shall be performed on new module designs, when a major design change has been implemented on an existing design, or after every 5 years that a design is in service. Modules used in design qualification testing shall be representative of the manufacturer's proposed normal production. The certification of UV Stabilization (5.4.5.2) shall be provided for all materials used in or on the emitting lenses. If modules are provided with both clear and tinted lenses, the tests per the stated section of the VTCSH below shall be conducted for all lens types. Refer to the Design Qualification Testing Flow Chart in the VTCSH:

Test	Paragraph
Temperature Cycling	5.4.3.2
Moisture Resistance	5.4.3.3
Luminous Intensity	5.4.4.1
Luminance Uniformity	5.4.4.5
Chromaticity	5.4.4.6
Color Uniformity	5.4.4.7
Lens Abrasion	5.4.5.2

5.4.1.1 Test data shall be retained by the manufacturer in accordance with Section 5.1.2 or for 60 months following final production of a specific design, whichever is longer.

5.4.1.2 Six modules shall be used in Design Qualification Testing. All six modules shall be subjected to conditioning (5.4.2), followed by the Environmental Tests (5.4.3). Following the Environmental Tests, three modules shall undergo Photometric & Colorimetric Tests (5.4.4), followed by the Lens Abrasion Test (5.4.5). The remaining three modules shall undergo the Electrical Tests (5.4.6), the Controller Assembly Compatibility Tests (5.4.7), and the Failed State Impedance Test (5.4.8). Tests shall be conducted in the order described herein, unless otherwise specified. Figure 2 provides a flow chart for the Design Qualification Testing.

5.4.1.3 In order for a module design to be considered acceptable for marking with the label described in 2.6.4, all tested modules must comply with the acceptance/rejection criteria for the Environmental Tests (5.4.3), Photometric & Colorimetric Tests (5.4.4), Lens Tests (5.4.5), Electrical Tests (5.4.6), Controller Assembly Compatibility Tests (5.4.7), and the Failed State Impedance Test (5.4.8).

5.4.2 Conditioning: Modules shall be energized for a minimum of 24 hours, at 100% duty cycle, in an ambient temperature of +60°C (+140°F).

5.4.3 Environmental Tests:

5.4.3.1 Mechanical Vibration: Mechanical vibration testing shall be performed per MIL-STD-883, Test Method 2007, using three 4 minute cycles along each x, y, and z axis, at a force of 2.5 Gs, with a frequency sweep from 2 Hz to 120 Hz.

5.4.3.2 Temperature Cycling: Temperature cycling shall be performed per MIL-STD-883, Test method 1010. The temperature range shall include the full ambient operating temperature range specified in 2.3.2. A minimum of 20 cycles shall be performed with a 30-minute transfer time between temperature extremes and a 30-minute dwell time at each extreme temperature. Signals under test shall be non-operating.

5.4.3.3 Moisture Resistance: Moisture resistance testing shall be performed per MIL-STD-810F, Test Method 506.4, Procedure I, Rain and Blowing Rain. The test shall be conducted on stand-alone modules, without a protective housing. The rainfall rate shall be 1.7 mm/min (4 in/hr) and droplet size shall predominantly be between 0.5 mm and 4.5 mm (0.02 to 0.18 in). The modules shall be vertically oriented, such that the lens is directed towards the wind source when at a zero rotation angle. The module shall be rotated at a rate of 4 degrees per minute along the vertical axis, from an orientation of -60 to +60 degrees during the test. The

duration of the test shall be 30 minutes. The modules shall be energized throughout the test. The water shall be at $25^{\circ} \pm 5^{\circ}\text{C}$ ($77^{\circ} \pm 9^{\circ}\text{F}$). The wind velocity shall be 80 km/hr (50 mph). If the module is equipped with a remote power supply unit, then the test shall be conducted with the remote power supply unit attached to the clamping device holding the module to the test apparatus.

5.4.3.4 Environmental Tests Evaluation: At the conclusion of the Environmental Tests, all the modules will be visual inspected for damage and energized to insure proper operation.

5.4.3.5 Acceptance/Rejection Criteria: The loosening of the lens, or any internal components, or evidence of other physical damage, such as cracking of the module lens or housing, or presence of internal moisture, or failure to operate correctly after testing shall be considered a failure for the proposed design.

5.4.4 Photometric & Colorimetric Tests: Three of the modules that were subjected to the Environmental Tests shall undergo Photometric & Colorimetric Tests. Unless otherwise specified, these tests shall be performed with the modules energized at nominal operating voltage.

5.4.4.1 Luminous intensity at standard temperature: The modules shall be tested for compliance with the requirements for minimum maintained luminous intensity at a temperature of 25°C (77°F). Measurements shall be made for all angular combinations specified in Table 1 or 3, as appropriate, or at other angles, as specified by the purchaser.

5.4.4.1.1 Luminous intensity measurements for red and green signal modules shall be made after the module has been operated under the test conditions for a minimum of 60 minutes at a 100% duty cycle.

5.4.4.1.2 Luminous intensity measurements for yellow signal modules shall be made after the module has been operated under the test conditions for a minimum of 60 minutes at a 12.5% duty cycle (5 seconds ON and 35 seconds OFF). Readings shall be taken at the end of the 5-second ON interval, or as close to the end of the ON interval as possible.

5.4.4.2 Luminous intensity at low voltage: The modules shall be tested for compliance with the requirements for minimum maintained luminous intensity when operated at 80 VAC at a temperature of 25°C (77°F). A single-point measurement of the luminous intensity shall be recorded, and correlated to the measurement made in the same direction under Section 6.4.4.1 to generate a full range of luminous intensity values at reduced voltage. For omni directional modules, the single point measurement shall be taken in the region from 7.5 degrees up to 7.5 degrees down and from 7.5 degrees left to 7.5 degrees right. The luminous intensity measurement at reduced voltage shall be made immediately following measurements for luminous intensity at standard temperature (5.4.4.1).

5.4.4.3 Luminous intensity at elevated voltage: The modules shall be tested for compliance with the requirements for minimum maintained luminous intensity when operated at 135 VAC at a temperature of 25°C (77°F). A single-point measurement of the luminous intensity shall be recorded, and correlated to the measurement made in the same direction under Section 5.4.4.1 to generate a full range of luminous intensity values at elevated voltage. The single point measurement shall be taken in the region described in Section 5.4.4.2. The luminous intensity measurement at elevated voltage shall be made immediately following measurements for luminous intensity at reduced voltage (5.4.4.2).

5.4.4.4 Luminous intensity at high temperature: The modules shall be tested for compliance with the requirements for minimum maintained luminous intensity at a temperature of 74°C (165°F). The modules shall be mounted in a temperature chamber so that the signal module lens is outside the chamber and all portions behind the lens are within the chamber at a temperature of 74°C (165°F). The air temperature in front of the lens of the signal shall be maintained at a minimum of 49°C (120°F) during all tests. A single-point measurement of the luminous intensity shall be recorded, and correlated to the 25°C (77°F) measurement made in the same direction under Section 5.4.4.1 to generate a full range of luminous intensity values at high temperature. The single point measurement shall be taken in the region described in Section 5.4.4.2.

5.4.4.4.1 Luminous intensity measurements for red and green modules shall be made after the module has been operated under the test conditions for a minimum of 60 minutes at a 100% duty cycle.

5.4.4.4.2 Luminous intensity measurements for yellow modules shall be made after the module has been operated under the test conditions for a minimum of 60 minutes at a 12.5% duty cycle (5 seconds ON and 35 seconds OFF). Readings shall be taken at the end of the 5-second ON interval, or as close to the end of the ON interval as possible.

5.4.4.5 Luminance uniformity: The modules shall be tested for compliance with the requirements for luminance uniformity at a temperature of 25°C (77°F). Measurements shall be made using a luminance meter located on the physical axis of the module lens at a distance such that the selected aperture samples a circular spot with a diameter of 12mm (0.5 inch) at the lens surface. The position of the luminance meter shall be translated from side to side and up and down, so as to sample the entire emitting surface of the module. The highest and lowest values of luminance shall be recorded. Luminance measurements may be made immediately following measurements for luminous intensity at standard temperature and elevated voltage (5.4.4.3), after returning the voltage to the nominal operating voltage (120VAC).

5.4.4.5.1 Luminance uniformity measurements for the green and red signals must be made with the signal module operating at a 100% duty cycle. Therefore, it is necessary for the signal module under test to reach thermal equilibrium, and for the output to be stable prior to taking measurements.

5.4.4.5.2 Measurements for yellow signal modules shall be made after the module has been operated under the test conditions for a minimum of 60 minutes at a 12.5% duty cycle (5 seconds ON and 35 seconds OFF). Readings shall be taken at the end of the 5-second ON interval, or as close to the end of the ON interval as possible.

5.4.4.6 Chromaticity: The chromaticity of the emitted light from modules shall be measured at a temperature of 25°C (77°F). A spectro-radiometer with a maximum bandwidth of 4nm, or a colorimeter that has a measurement uncertainty of less than 2.5% over the emission spectra of the module, shall be used for this measurement. The spectro-radiometer or colorimeter shall be located on the physical axis of the module lens at a distance such that the selected aperture samples a circular spot with a diameter of 12mm (0.5 inch) at the lens surface. The meter shall be translated from side to side and up and down, so as to sample a minimum of nine equally distributed positions about the emitting surface of the module. The colorimetric values of the emitted light at each of the nine positions shall be recorded, and an average value calculated, based on the CIE Standard 2° Observer. These measurements may be made immediately following measurements for luminance uniformity (5.4.4.5).

5.4.4.6.1 Chromaticity measurements for the green and red signals must be made with the signal module operating at a 100% duty cycle. Therefore, it is necessary for the signal module under test to reach thermal equilibrium, and for the output to be stable prior to taking measurements.

5.4.4.6.2 Measurements for yellow signal modules shall be made after the module has been operated under the test conditions for a minimum of 60 minutes at a 12.5% duty cycle (5 seconds ON and 35 seconds OFF). Readings shall be taken at the end of the 5-second ON interval, or as close to the end of the ON interval as possible. If necessary, the ON interval may be extended to 10 seconds to permit completion of a measurement. The ON interval between measurements, however, shall remain 5 seconds.

5.4.4.7 Color uniformity: The average and nine individual sets of chromaticity values of each module under evaluation shall be plotted on the CIE 1931 Chromaticity Diagram (see Figure 1, VTCSH LED Circular Signal Supplement).

5.4.4.8 Photometric & Colorimetric Tests Evaluation: At the conclusion of the Photometric & Colorimetric Tests, the measurement data shall be compared to the applicable requirements of Sections 3.1 and 3.2.

5.4.4.9 Acceptance/Rejection Criteria: The failure of a module to meet any of the following: the requirements for minimum maintained luminous intensity (3.1.1) or maximum permissible luminous intensity (3.1.2) under standard and high temperatures, the requirement for luminance uniformity (3.1.3), or the appropriate requirement for chromaticity (3.2) shall be considered a failure of the proposed design.

5.4.5 Lens Tests: Following the Photometric & Colorimetric Tests, the three modules shall be subjected to the following tests of the acceptability of the lens construction.

5.4.5.1 UV Stabilization: Documentation shall be provided that certifies that the loss of direct transmission through the lens shall not cause the performance of the module to fall below the photometric requirements, or deviate from the colorimetric requirements of this specification after 60 months, or greater as specified by the manufacturer, of service in accordance with 2.3.1 and 2.3.4. Documentation shall be provided for hard-coat film (if used) and lens material.

5.4.5.2 Lens Abrasion Test: Abrasion resistance testing of the module lens shall be performed as follows:

- a) A lens shall be mounted in the abrasion test fixture with the lens facing upwards.
- b) An abrading pad meeting the requirements in paragraphs c) through f) below shall be cycled back and forth (1 cycle) for 12 cycles at $10\text{cm} \pm 2\text{cm}$ per second over the whole surface of the lens.
- c) The abrading pad shall be not less than $2.5\text{cm} \pm 0.1\text{cm}$ square, constructed of 0000 steel wool and rubber, cemented to a rigid base shaped to the same contour as the lens. The “grain” of the pad shall be perpendicular to the direction of motion.
- d) The abrading pad support shall be equal in size to the pad and the center of the support surface shall be within $\pm 2\text{mm}$ of parallel to the lens surface.
- e) The density of the abrading pad shall be such that when the pad is mounted to its support and is resting unweighted on the lens, the base of the pad shall be no closer than 3.2mm to the lens at its closest point.
- f) When mounted on its support and resting on the lens, the abrading pad shall be weighted such that a pad pressure of $14\text{ kPa} \pm 1\text{ kPa}$ exists at the center and perpendicular to the face of the lens.
- g) A pivot shall be used if required to follow the contour of the lens.
- h) Unused steel wool shall be used for each test.

5.4.5.3 Acceptance/Rejection Criteria: The photometric performance of a module following the lens abrasion test shall be 90% or more of the photometric performance of the same module measured prior to the lens abrasion test. A single point correlation as described in 5.4.4.2 may be used to determine the change in photometric performance. The single point measurement shall be made at an ambient temperature of 25°C (77°F) and nominal voltage of 120VAC. Failure of any module to meet the requirement for photometric performance following the lens abrasion test shall be considered a failure of the proposed design.

5.4.6 Electrical Tests: Three of the modules that were subjected to the Environmental Tests shall undergo Electrical Tests. These tests shall be performed with the modules energized at nominal operating voltage and at a standard temperature of 25°C (77°F), unless specified otherwise.

5.4.6.1 Current Consumption: The current flow, in Amperes, shall be measured at various ambient temperatures across the span of the operating temperature range specified in 2.3.1. The manufacturer shall provide information (charts, tables and/or graphs) on the variation in current through 60 months of service, or greater as specified by the manufacturer, within the operating temperature range of 2.3.2. In addition, the current consumption at start-up shall be measured at 25°C (77°F) to establish the reference value used for Production Quality Assurance (5.3.4).

5.4.6.2 Low-Voltage Turn-OFF: The modules shall be connected to a variable power supply, and energized at nominal operating voltage. The applied voltage shall be reduced to a point where there is no visible illumination from the module when the background is at an average luminance of 0.1 cd/m² (0.01 ft-cd).

5.4.6.3 Turn-ON/Turn-OFF Times: Using a two-channel oscilloscope, the time delay between application of nominal operating voltage and the module reaching 90% of full light output, and the time delay between de-energizing the module and the light output dropping to 0% of full output, shall be measured.

5.4.6.4 Transient Voltage Immunity: The modules shall be tested for transient immunity using the procedure described in Section 2.1.8, NEMA Standard TS 2-2003.

5.4.6.5 Electronic Noise: The modules shall be tested for conformance with the requirements of a Class A digital device, as specified in FCC Title 47, Subpart B, Section 15.109(b).

5.4.6.6 Power Factor: The power factor for the modules shall be measured and recorded. A commercially available power factor meter may be used to perform this measurement.

5.4.6.7 Total Harmonic Distortion (THD): The total harmonic distortion induced into an AC power line by the modules shall be measured and recorded. A commercially available total harmonic distortion meter may be used to perform this measurement.

5.4.6.8 Electrical Tests Evaluation: At the conclusion of the Electrical Tests, the measurement data shall be compared to the requirements of Sections 4.2 through 4.5.

5.4.6.9 Acceptance/Rejection Criteria: The failure of any module to meet the requirements for low-voltage turn-OFF (4.2.4), turn-ON/turn-OFF times (4.2.5), transient voltage immunity (4.3), emission of electronic noise (4.4), minimum power factor (4.5.1), and/or maximum total harmonic distortion (4.5.2) shall be considered a failure of the proposed design.

5.4.7 Controller Assembly Compatibility Tests: Following the Electrical Tests, three modules shall be tested for compatibility with load current switches and conflict monitors presently in service. The manufacturer shall test the design for the specific type signal control unit with which the design is intended to be compatible.

5.4.7.1 Load Switch Compatibility: The modules shall be tested for compatibility and proper operation with load current switches. Each module shall be connected to a variable AC voltage supply. The AC line current into the module shall be measured for sufficient current draw to ensure proper load switch operation while the voltage is varied from 80 to 135 VAC.

5.4.7.2 Off State Voltage Decay Test: Each module shall be operated from a 135 VAC voltage supply. A 19.5 kΩ resistor shall be wired in series in the hot line between the module and the AC power supply. A single-pole-single-throw switch shall be wired in parallel with the 19.5 kΩ resistor. A 220 kΩ shunt resistor shall be wired between the hot line connection and the neutral line connection on the module. Conflict monitor Off state impedance compatibility shall be tested by measuring the voltage decay across the 220 kΩ shunt resistor as follows: The single-pole-single-throw switch shall be closed, bypassing the 19.5 kΩ resistor and allowing the AC power supply to energize the module. Next, the switch shall be opened and the voltage across the 220 kΩ shunt resistor shall be measured for decay to a value equal to or less than 10 VAC RMS. The test shall be repeated 10 times, with the longest decay time recorded as the final test value.

5.4.7.3 Controller Assembly Compatibility Tests Evaluation: At the conclusion of the Controller Assembly Compatibility Tests, the measurement data shall be compared to the requirements of Section 4.6.

5.4.7.4 Acceptance/Rejection Criteria: Failure of the module to draw sufficient current to ensure compatibility with the load current switches in the appropriate Controller Assembly (4.6.1) and/or failure of the circuit voltage to decay to a value equal to or less than 10 VAC RMS within a time period equal to or less than 100 milliseconds (4.6.2) shall be considered a failure of the proposed design.

5.4.8 Failed State Impedance Test: The modules shall be tested for compliance with the requirement for provision of a failed-state impedance (4.7). The test is conducted in two parts: first the module is energized with the LED load disconnected from the power supply to establish the failed-state impedance. Next, the requirement for the failed state impedance is tested. The module shall be operated from a 120 VAC voltage supply.

- a) Wire a 50 k Ω resistor in series with the hot line between the module and the AC power supply. A 100 k Ω shunt resistor shall be wired between the hot line connection and the neutral line connection on the module. A single-pole-single-throw switch shall be wired in parallel with the 50 k Ω resistor. With the switch in the closed position and the LED load disconnected from the module power supply, energize the module for 300ms to establish the failed state impedance (4.7.2).
- b) The second part of the failed state impedance test is conducted to insure that the appropriate failed state impedance is established. The switch is opened and the circuit is energized by the 120VAC voltage supply. The voltage across the 100 k Ω shunt resistor shall be continuously monitored. The voltage shall decay to a value equal to or greater than 70 VAC RMS. For the continuous interval of 500 ms through 1500 ms, after energizing the circuit with an open switch, the measured voltage shall be 70 VAC RMS or greater. The second part of the test shall be repeated 10 times, with the minimum voltage recorded during the continuous interval of 500 ms through 1500 ms, after energizing the circuit with an open switch, recorded as the final test value.

5.4.8.1 Failed State Impedance Test Evaluation: At the conclusion of the Failed State Impedance Test, the measurement data shall be compared to the requirement of Section 4.7.

5.4.8.2 Acceptance/Rejection Criteria: Failure of the voltage across the 100 k Ω shunt resistor to remain at a value equal to or greater than 70 VAC RMS for the continuous time interval of 500 ms through 1500 ms, after energizing the circuit with an open switch, shall be considered a failure of the proposed design.

6.0 Warranty Requirements

6.1 Warranty

6.1.1 Manufacturers shall provide a written warranty issued by the factory located in the NAFTA country of module origin with the following minimum provisions:

6.1.2 Modules shall, at the manufacturer's option, be repaired or replaced if the module fails to function as intended due to workmanship or material defects within the first 60 months from the date of delivery.

6.1.3 Modules shall, at the manufacturer's option, be repaired or replaced if the module exhibit luminous intensities less than the minimum specified values within the first 60 months of the date of delivery.

6.1.4 Upon request, the LED lamp module manufacturer shall provide written documentation of its ability to satisfy a worst-case, catastrophic warranty claim.

6.1.4.1 A current corporate annual report duly-certified by an independent auditing firm, containing financial statements illustrating sufficient cash-on-hand and net worth to satisfy a worst-case, catastrophic warranty claim is an example of suitable documentation.

6.1.4.2 The documentation shall clearly disclose:

- a) The country in which the factory of module origin is located
- b) The name of the company or organization that owns the factory of module origin including any and all of its parent companies and/or organizations, and their respective country of corporate citizenship

6.1.4.3 For firms with business and/or corporate citizenship in the United States of less than seven years, the process by which the end-users/owners of the modules will be able to obtain worst-case, catastrophic warranty service in the event of bankruptcy or cessation-of-operations by the firm supplying the modules within North America, or in the event of bankruptcy or cessation-of-operations by the owner of the factory of origin, shall be clearly disclosed.

Figure 1.
Intertek- ETL Verified Label



Table 1

Table 1 provides the minimum maintained luminous intensity values for the VTCSH Omni-directional LED Vehicle Arrow Traffic Signal, for the range from 27.5 degrees above to 27.5 degrees below the horizontal plane, and from 27.5 degrees left to 27.5 degrees right of the vertical plane, at 5 degree increments.

Minimum Maintained Luminous Intensity Value
Per VTCSH LED Vehicle Arrow Traffic Signal, July 1, 2007
(Omni-directional—suitable for mounting in any orientation)

Vertical Angle (deg)	Horizontal Angle (deg)	Omni-directional Angle (deg)	Luminous Intensity (candela)		
			300mm (12 in) Arrow Signal		
			Red	Yellow	Green
27.5	7.5	28.4	2.8	6.9	3.6
	2.5	27.6	3.3	8.2	4.3
22.5	17.5	28.2	2.9	7.2	3.8
	12.5	25.6	5.0	12.4	6.4
	7.5	23.7	7.1	17.7	9.2
	2.5	22.6	8.5	21.2	11.1
17.5	22.5	28.2	2.9	7.2	3.8
	17.5	24.6	6.0	15.0	7.8
	12.5	21.4	10.5	26.1	13.6
	7.5	19.0	15.1	37.7	19.7
	2.5	17.7	18.2	45.3	23.7
12.5	22.5	25.6	5.0	12.4	6.4
	17.5	21.4	10.5	26.1	13.6
	12.5	17.6	18.3	45.7	23.9
	7.5	14.5	26.7	66.5	34.7
	2.5	12.7	32.1	80.1	41.8
7.5	27.5	28.4	2.8	6.9	3.6
	22.5	23.7	7.1	17.7	9.2
	17.5	19.0	15.1	37.7	19.7
	12.5	14.5	26.7	66.5	34.7
	7.5	10.6	38.9	97.0	50.6
	2.5	7.9	47.0	117.1	61.1
2.5	27.5	27.6	3.3	8.2	4.3
	22.5	22.6	8.5	21.2	11.1
	17.5	17.7	18.2	45.3	23.7
	12.5	12.7	32.1	80.1	41.8
	7.5	7.9	47.0	117.1	61.1
	2.5	3.5	56.8	141.6	73.9

Note 1: Luminous intensity values for equivalent up and down vertical angles are the same.

Note 2: Luminous intensity values for equivalent left and right horizontal angles are the same.

Note 3: Tabulated values of luminous intensity are rounded to the first decimal place.

Figure 2

Configuration of LED Vehicle Arrow Traffic Signal Icon:

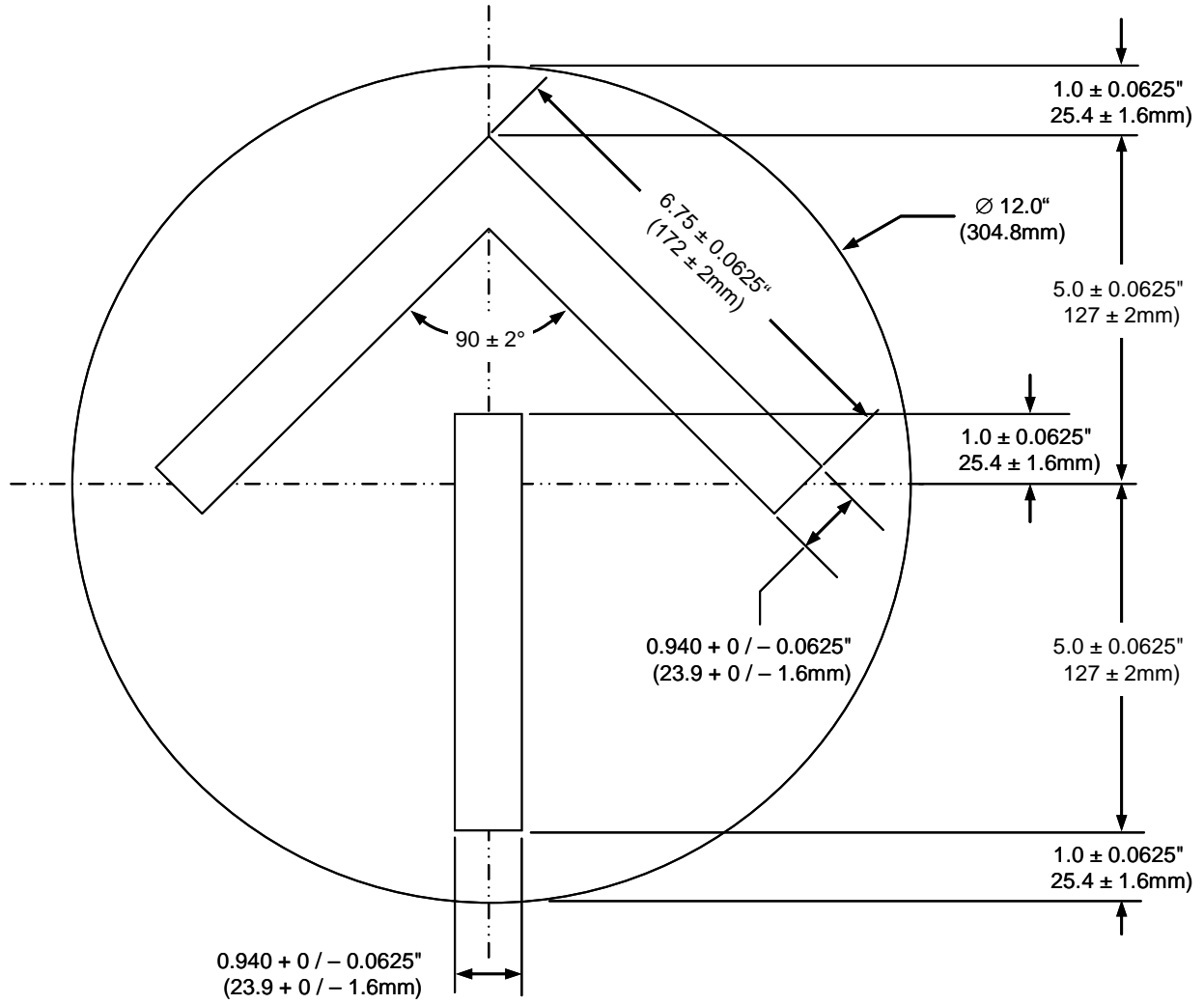

Table 2. LED Module Supplier Checklist

Below checklist must be completed and provided with this submission. Substantiation data must be submitted in either book form or electronic (disc) format. In all cases the substantiation data being submitted must be indexed and tabulated referencing the appropriate article number.

Vendor / Manufacturer Information:

Distributor Name:

Address:

City:

State:

Contact Name:

Contact Phone No.

LED Module Manufacturer:

Name:

Address:

City:

State:

Contact Name:

Contact Phone No.

LED Module Manufacturing Location:

Address:

City:

State:

Country:

Led Signal Modules Manufacture's Part Numbers

	12" (300 mm) Arrow
Red Arrow	
Yellow Arrow	
Green Arrow	

Section	Requirements Per ITE VTCSH Omni-Directional Arrow Traffic Signal Supplement, July 1,2007 and Additional Requirements Specified by this Document	Comply Y / N ¹	Substantiation Requirements
1.2. Manufacturers Requirements			
1.2.1	Manufacture participated in Intertek-ETL LED Traffic Signal Module Certification program and proposed base products are listed on the ETL website for the program.		Provide letter of participation from ETL and copy of web page from ETL web site showing product listing.
1.2.2	All Modules produced in NAFTA participating country.		Provide Statement of Country of Origin on Manufacturer's letterhead.
1.2.3	All Modules shall be CSA approved.		Provide copy of CSA Approval Certificate.
2. Physical & Mechanical Requirements – Summary			
2.1.1	Stand-alone units shall fit into VTCSH approved traffic signal housings without modification to the housing.		
2.1.2	Installation of LED modules shall not require special tooling and shall connect directly to the exiting electrical wiring system.		
2.2.1	LED module shall be capable of replacing existing optical components of the conventional signal head.		
2.2.2	The module front lens shall be hard coated and compliant to the SAE J576 requirement under ITE 6.4.5.2 test methodology on material exposure and weathering effects.		Provide letter of compliance for materials supplier.
2.2.3	Lens color to be supplied with tinting or clear as specified.		Attached manufacturer's data sheet detailing product.
2.2.4	Exterior convex lens with smooth outer surface to minimize build-up of dust and dirt.		
2.2.5	Arrow Size and shape conforms to Figure 2.		
2.2.6	The LEDS shall be suitable for outdoor applications and not be AlGaAs Technology.		Provide a copy of the Data Sheet for the LEDs utilized in the Arrow Traffic Module.
2.3.1	All exposed components shall be suitable for prolonged exposure to the environment without interfering to the function or appearance for a period of at least 60 months (in a south-facing Arizona desert).		Provide letter of compliance for materials supplier.
2.3.2	All modules shall be rated for use throughout an ambient operating temperature range, measured at the exposed rear of the module, of -40°C to + 74°C as per ITE 6.4.3.2 temperature cycling according to MIL-STD- 883, test method 1010.		Intertek Independent test lab results required.
2.3.3	A module shall be protected against dust and moisture intrusion, including rain and blowing rain. (MIL-STD-810F, test method 506.4, procedure 1, Rain and Blowing Rain under ITE 6.4.3.3 test methodology).		Intertek Independent test lab results required.
2.4.1	A module shall be self-contained, not requiring on-site assembly. Power supply shall be integral to the module.		Intertek ETL test lab results Report # _____ Date of Report _____ Page # _____
2.4.2	Assembly and manufacturing processes for a module shall be designed that all internal LED and electronic components withstand mechanical shock and vibration due to high wind and other sources. (MIL-STD-883, test method 2007 under ITE 6.4.3.1 test methodology).		Intertek ETL test lab results Report # _____ Date of Report _____ Page # _____

Section	Requirements Per ITE VTCSH Omni-Directional Arrow Traffic Signal Supplement, July 1,2007 and Additional Requirements Specified by this Document	Comply Y / N ¹	Substantiation Requirements
2.5.1	Materials used for the lens and module construction shall conform to ASTM specifications for the materials, where applicable.		
2.5.2	LED module enclosure that contains the power supply shall be made of UL94 flame retardant materials.		
2.6.1	Each module shall be identified with manufacturer's name, model, operating characteristics (nominal voltage and stabilized power consumption) and serial number.		Provide sample label showing required marking.
2.6.2	Modules must be clearly marked "Suitable for mounting in any orientation".		Provide Photographs or drawings showing designators
2.6.3	All modules shall be marked with a statement that they are manufactured in conformance with the ITE LED Vehicle Arrow Traffic Signal Supplement.		Provide sample copy of manufacturer's label.
2.6.4	Modules to be labeled with Intertek-ETL verified label.		Provide drawing of label to be used.
3. Photometric Requirements – Summary			
3.1.1	<p>Minimum Maintained Luminous intensity must be maintained over the temperature range of -40°C to +74°C for red, yellow, and green over the voltage range of 80 to 135 V AC for a minimum period of 60 months, in accordance with ITE Vehicle Arrow Traffic Signal Supplement requirements.</p> <p>NOTE: The test report from independent lab only represents lamp performance at day 1. Manufacturer shall therefore, provide a written warranty that all modules will remain compliant to the ITE Circular Signal Supplement Table 1 (minimum maintained luminous intensity) for 60 months, at the ITE specified high ambient temperature of 165°F.</p>		Intertek ETL test lab results Report # _____ Date of Report _____ Page # _____
3.1.2	Maximum permissible luminous intensity shall not exceed three times the required peak value of the minimum maintained luminous intensity for the selected signal size and color.		Intertek ETL test lab results Report # _____ Date of Report _____ Page # _____
3.1.3	The uniformity of the luminance (cd/m ²) across the entire module lens shall not exceed a max/min ratio of 10 to 1. (As per ITE VTCSH 6.4.4.5, 6.4.4.5.1 and 6.4.4.5.2 test methodology).		Intertek ETL test lab results Report # _____ Date of Report _____ Page # _____
3.2.1	Color regions: the measured chromaticity coordinates of modules shall conform to the following: Red: $y=0.308$, $y=0.953-0.947x$; $y=0.290$; Yellow: $y=0.151 + 0.556x$, $y=0.972 - 0.976x$; $y=0.235 + 0.300x$; Green: $y=0.655 - 0.831x$, $x=0.150$; $y=0.422-0.278x$. (ITE VTCSH 6.4.4.6, 6.4.4.6.1 and 6.4.4.6.2 test methodology).		Intertek ETL test lab results Report # _____ Date of Report _____ Page # _____
3.2.2	Color Uniformity: The dominant wavelength for any individual color measurement of a portion of the emitting surface of a module shall be within + or - 3 nm of the dominant wavelength for the average color measurement of the emitting surface as a whole. (As per ITE VTCSH 6.4.4.7 test methodology).		Intertek ETL test lab results Report # _____ Date of Report _____ Page # _____
4.0 Electrical Requirements			
4.1	General: Wire consist of two secured, color coded, 600 V, jacketed wires, a minimum length of 39", 20 AWG, 105°C rated, conforming to NFPA 70. Wire is anti-capillary type.		Provide wire specification.

Section	Requirements Per ITE VTCSH Omni-Directional Arrow Traffic Signal Supplement, July 1,2007 and Additional Requirements Specified by this Document	Comply Y / N ¹	Substantiation Requirements
4.1.2	Wire colors shall be red and white on the red arrows, yellow and white on the yellow arrows, and brown and white on the green arrow modules.		
4.1.3	AC wires shall exit the module via a rubber grommetted strain relief. Wire shall be terminated with insulated female quick connect terminals with spade / tab adapters.		
4.1.3.1	All external wire types shall be anti-capillary type to prevent the wicking of moisture.		Provide wire specification.
4.1.4	Module power supplies are conformal coated.		Provide data sheet for the coating being used.
4.2.1	Voltage range of 80 to 135 VAC RMS, operate off a 60 Hz AC line (As per ITE 6.4.4.2 and 6.4.4.3 test methodology).		Intertek ETL test lab results Report # _____ Date of Report _____ Page # _____
4.2.2	Fluctuations over the voltage range of 80 to 135 VAC shall not affect the luminous intensity by more than + or - 10% (As per ITE 6.4.4.2 and 6.4.4.3 test methodology).		Intertek ETL test lab results Report # _____ Date of Report _____ Page # _____
4.2.3	The module shall prevent flicker of the LED output at frequencies less then 100 Hz over the voltage range of 80 to 135 V AC RMS.		
4.2.4	Low voltage turn OFF: there shall be no visible illumination from the LED signal module when the applied voltage is less than 35 V AC (As per ITE 6.4.6.2 test methodology).		Intertek ETL test lab results Report # _____ Date of Report _____ Page # _____
4.2.5	Turn ON time: A module shall reach 90 % of full illumination within 75 msec of the application of the nominal operating voltage, Turn OFF time: The signal shall cease emitting visible illumination within 75 msec of the removal of the nominal operating voltage. (As per ITE 6.4.6.3 test methodology).		Intertek ETL test lab results Report # _____ Date of Report _____ Page # _____
4.3.1	Transient Voltage Protection: LED module shall withstand NEMA standard TS-2-2003, section 2.1.8 (As per ITE 6.4.6.4 test methodology).		Intertek ETL test lab results Report # _____ Date of Report _____ Page # _____
4.3.1.1	Module Power supplies shall be capable of passing the surge test requirements as specified by ANSI/IEEE C62-41.2-2002 6KV 100 kHz Ring-wave 30 ohms.		Supply certificate of compliance from power supply manufacturer or test report.
4.4	Emission of Electronic noise shall meet FCC Title 47, Subpart B, section 15 for class A digital device.		Intertek ETL test lab results Report # _____ Date of Report _____ Page # _____
4.5.1	Power Factor of .90 or greater at nominal voltage and 25°C (As per ITE 6.4.6.6 test methodology).		Intertek ETL test lab results Report # _____ Date of Report _____ Page # _____

Section	Requirements Per ITE VTCSH Omni-Directional Arrow Traffic Signal Supplement, July 1,2007 and Additional Requirements Specified by this Document	Comply Y / N ¹	Substantiation Requirements
4.5.2	THD shall not exceed 20% @ 25°C (As per ITE 6.4.6.7 test methodology).		Intertek ETL test lab results Report # _____ Date of Report _____ Page # _____
4.5.3	Typical power @ 25°C for all colors shall not exceed 6 Watts.		Intertek ETL test lab results Report # _____ Date of Report _____ Page # _____
4.6.1	Sufficient current draw to ensure compatibility and proper triggering and operation of the load switches and conflict monitors in signal controller units. (As per ITE 6.4.7.1 test methodology).		Intertek ETL test lab results Report # _____ Date of Report _____ Page # _____
4.6.2	Off state Voltage Decay: Voltage shall decay to less than 10 VAC RMS in less than 100 ms when switched from On to OFF state if maximum load switch leakage current is 10 MA peak. (As per ITE 6.4.7.2 test methodology).		Intertek ETL test lab results Report # _____ Date of Report _____ Page # _____
4.7	Failed State Impedance: The module shall be designed to detect catastrophic loss of the LED load. Upon sensing loss of the LED load, the module shall present a resistance of at least 250 Kohms across the input power leads within 300 msec. The LED light source will be said to have failed catastrophically if it fails to show any visible illumination when energized according to Section 5.2.1 after 75 msec. (As per ITE 6.4.8 test methodology).		Intertek ETL test lab results Report # _____ Date of Report _____ Page # _____
5.0 Quality Assurance			
5.1.2	Vendor Records maintained for 7 years.		
5.2	Modules identified with information required per section 2.6.		Provide sample copy of manufacturer's label.
5.3	All modules are tested and inspected per the production test requirements of section 5.3.		
5.4	Intertek ETL Test Report must be supplied for all products demonstrating compliance to the design qualification requirements of section 5.4 of this document and section 6.4 of the ITE VTCSHLED Circular Signal Supplement dated June 27, 2005.		Intertek-ETL test reports Report # _____ Date of Report _____
6.0 Warranty Requirements			
6.1.1	Manufacturer shall issue a written warranty statement, stating compliance with the warranty provisions of this document.		Attach Manufacturer's Warranty Statement.
6.1.2	Module to be repaired or replaced, if the module fails to function as a result of workmanship or material defects within 60 months of date of delivery.		Attach Manufacturer's Warranty Statement.
6.1.3	Modules that fail to comply with the minimum intensity requirements within the first 60 months shall, at the manufacturer's option, be repaired or replaced.		Attach Manufacturer's Warranty Statement.

¹ For all sections above where non-compliance is indicated, please provide a detailed explanation on a separate sheet.