

NOTE:  
 1.- USE 4043 WELD WIRE.  
 2.- 6063 ASSEMBLY .375 WALL OR LESS TO BE HEAT-TREATED TO T6 TEMPER AFTER WELDING.

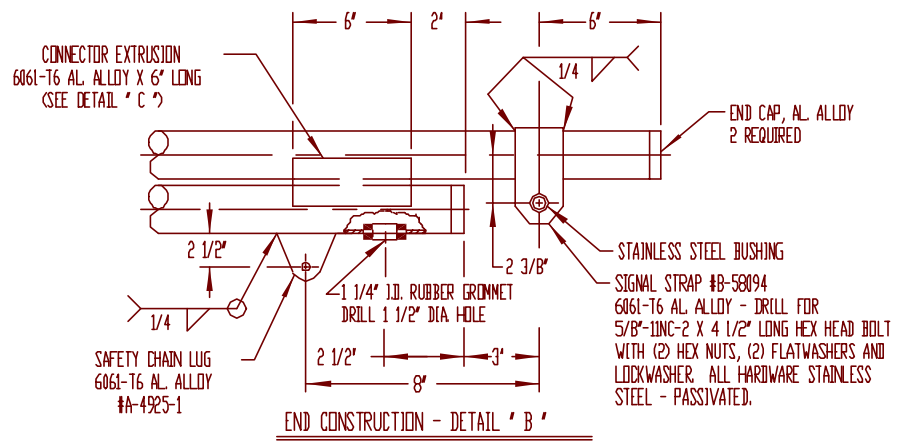
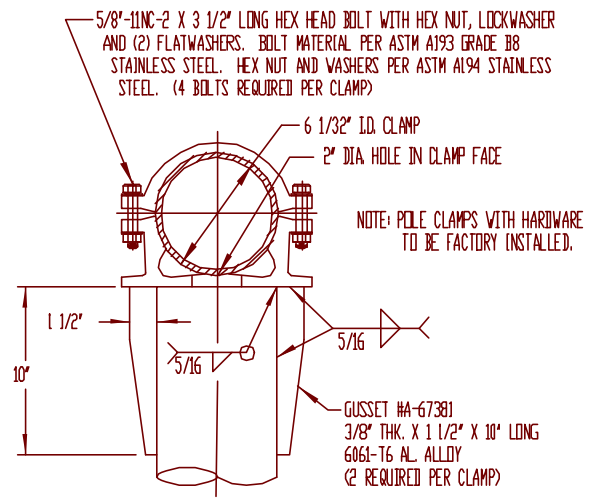
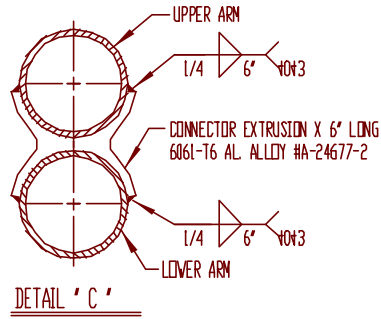

P&K

P&K POLE PRODUCTS, INC. 84 Foundry St, Newark, N.J.				
TITLE 20 FT. MAST ARM ASSEMBLY MA2050560-10				
BY AJP.	DATE 05-13-78	BY SFG.	DATE 05-13-78	DWG NO. C-68054
CHKD SFG.	DATE 05-13-78	CHKD SFG.	DATE 05-13-78	
CUSTODY NEW JERSEY DEPT. OF TRANSPORTATION			NONE	