

NOTE:
1.- USE 4043 WELD WIRE.
2.- 6063 ASSEMBLY .375 WALL OR LESS TO BE HEAT-TREATED TO T6 TEMPER AFTER WELDING.

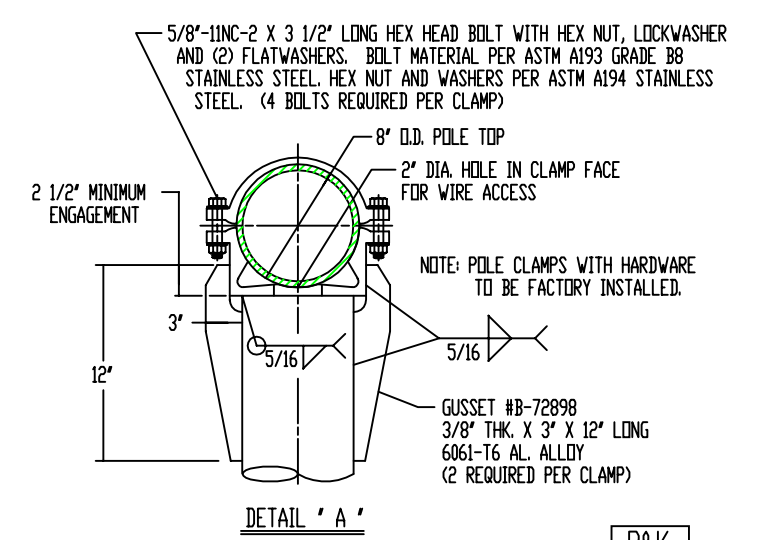
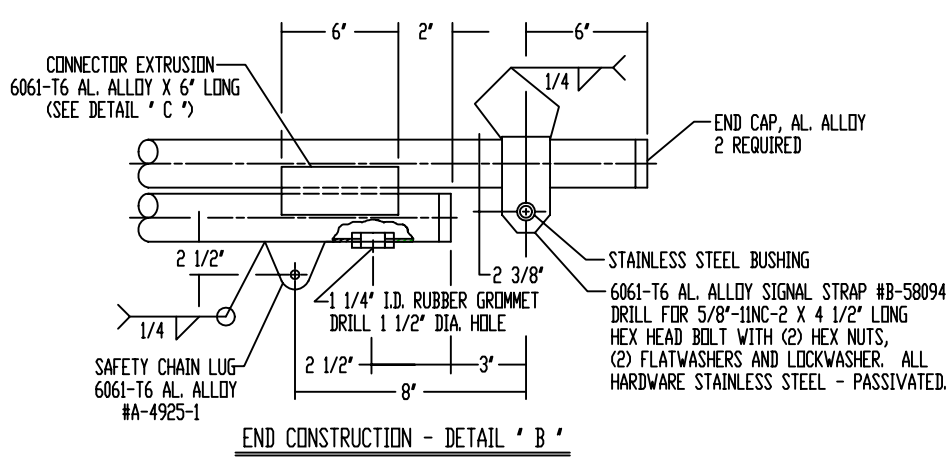
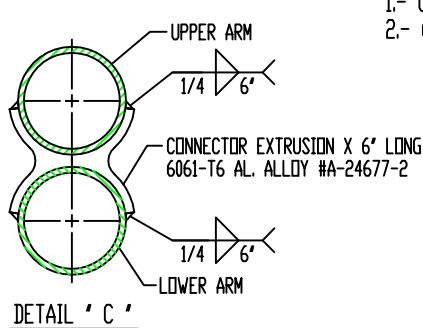

P&K

MATERIAL					P&K POLE PRODUCTS, INC. 84 Foundry St., Newark NJ	
STOCK SIZE					TITLE	
FINISH OR TEMPER					BERGEN CODE " MA20-10 "	
					MA2050880-70	
					DR. M.M.S.	05-12-95
					CHK. W.W.V.	05-12-95
					APP.	
CUSTOMER					SCALE	
BERGEN COUNTY DEPT. OF PUBLIC WORKS					NONE	
					C-105471	