

1'-8NC-2 X 3' LONG HEX HEAD BOLT, LOCKWASHER AND FLATWASHER - H.R.S. - GALV. (4 OF EACH REQUIRED)

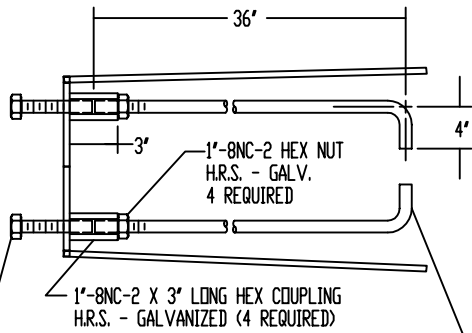

1' DIA. X 40' LONG ANCHOR ROD (4 REQUIRED). ANCHOR ROD TO BE 55,000 PSI MIN. YIELD STRENGTH PER AASHTO M314-90, GRADE 55. TOP 12" OF ROD TO BE GALVANIZED PER AASHTO M232 CLASS C, (ASTM A 153).

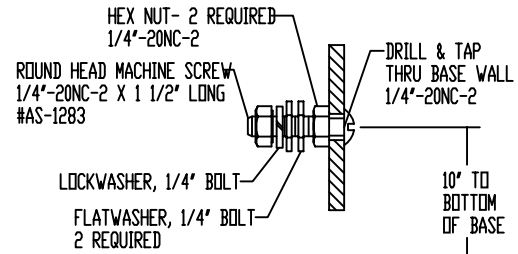

GROUNDING - DETAIL ' B ' (ALL HARDWARE STAINLESS STEEL - PASSIVATED)

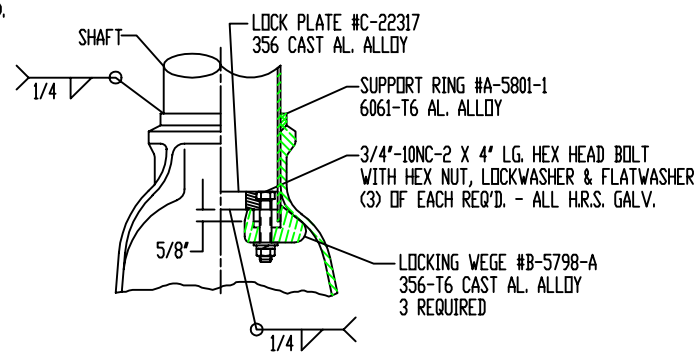

DETAIL ' A '

6061-T4 AL. ALLOY POLE CAP WITH (3) 1/4'-20NC-2 ST. STL. ALLEN HEAD CUP POINT SET SCREWS

DRILL 1 1/2" DIA. HOLE - INSTALL 1 1/4" I.D. RUBBER GROMMET

6063-T6 AL. ALLOY SHAFT 8" O.D. X .250 WALL TAPERED 8" X 6 5/8"

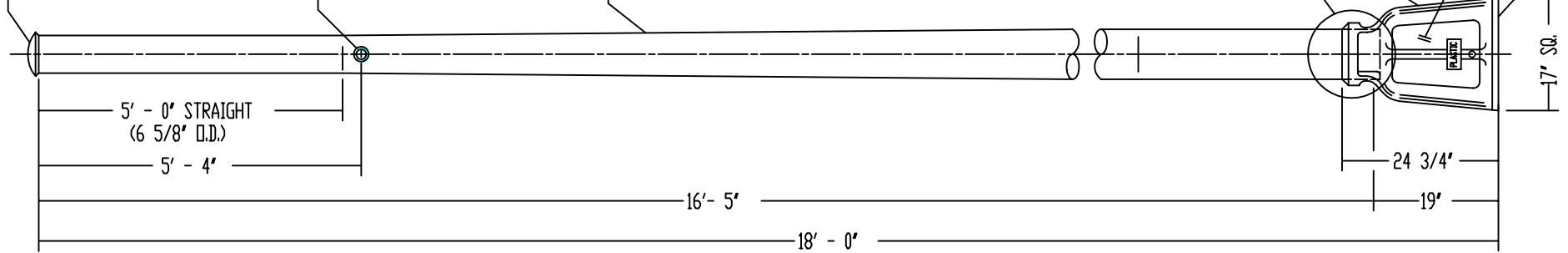

SEE DETAIL ' A '
 356-T6 CAST AL. ALLOY TRANSFORMER BASE TYPE TB-IR WITH GROUND SCREW PER DETAIL ' B '
 1/4" THK ABS PLASTIC DOOR ASSEMBLY WITH ULTRA-VIOLET INHIBITORS (OUTSIDE SURFACE OF DOOR TO HAVE 2" X 3" SELF-ADHESIVE LABEL)
 BOTTOM OF BASE TO BE COATED WITH BITUMINOUS PAINT

NOTE:
 1. - USE 4043 WELD WIRE.
 2. - 6063 ASSEMBLY .375 WALL OR LESS TO BE HEAT-TREATED TO T6 TEMPER AFTER WELDING.

P&K

AL. A DESCRIPTION: WAS 15" BOLT CIRCLE DATE: 06-19-93 BY: W.V. CH: W.V.				MATERIAL: SPEC. SIZE: FINISH OR TEMPER:	P&K POLE PRODUCTS, INC. 84 Foundry St., Newark, N.J. TITLE: S8066018003H-70 BERGEN CODE ST08-1800 DR. M.M.S. 10-18-86 CH. W.V.V. 10-18-86 APP. SCALE: NONE C-91176
CHECKED: BERGEN COUNTY DEPT. OF PUBLIC WORKS				MATERIAL:	DRG. NO.